

# ARKET

Studio Eurolinea Design, 2019

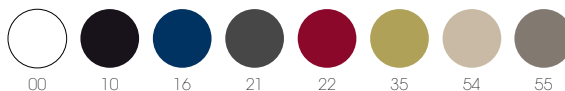

## FRAME FINISHES



Arket tables collection is made using basic geometrics and intuitive shapes. The table tops are made of Steel with Marine MDF core, the three or four spokes bases with adjustable feet and aluminium stems come in sections with three or four surfaces made of co-injected metal and technopolymer. Steel tables are painted in a solid color.

La collezione di tavoli Arket è realizzata utilizzando geometrie elementari e forme essenziali. I piani del tavolo sono realizzati in Acciaio con anima in MDF marino, la base a tre o quattro razze con piedini regolabili, steli, a sezioni con tre o quattro superfici, realizzati in metallo co-iniettati con tecnopolimero. I tavoli Steel sono verniciati in tinta unita.

---

## PERFORMED TEST

1. Safety requirements EN 15372:2016, clause 5.1 - 5.2
2. Information for use EN 15372:2016, clause 6
3. Horizontal static load test EN 1730:2012, clause 6.2
4. Vertical static load test EN 1730:2012, clause 6.3
5. Horizontal fatigue test EN 1730:2012, clause 6.4.2
6. Vertical fatigue test EN 1730:2012, clause 6.5
7. Vertical impact test EN 1730:2012, clause 6.6
8. Drop test EN 1730:2012, clause 6.9
9. Stability under vertical load EN 1730:2012, clause 7.2

**CATAS**

## STEEL TOP FINISHES

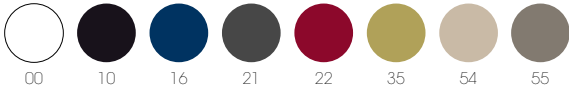

## STEEL AVAILABLE DIMENSIONS

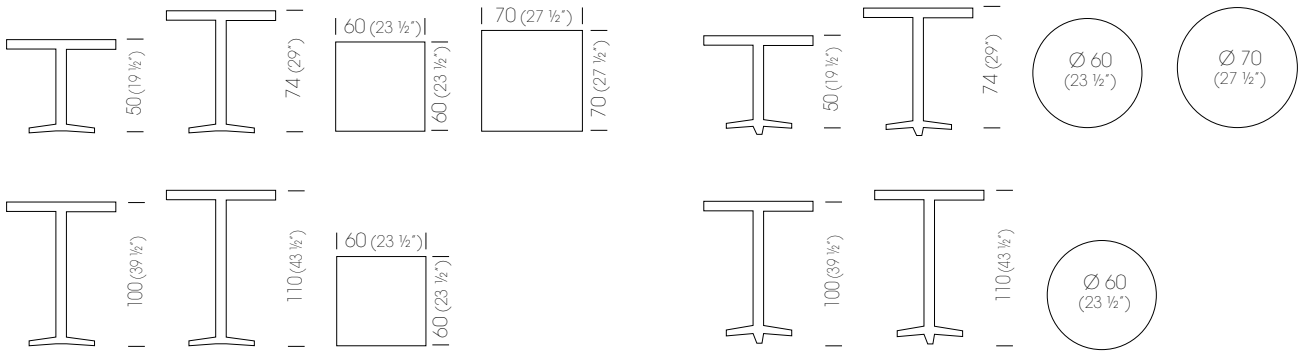

## PORCELAIN AVAILABLE DIMENSIONS

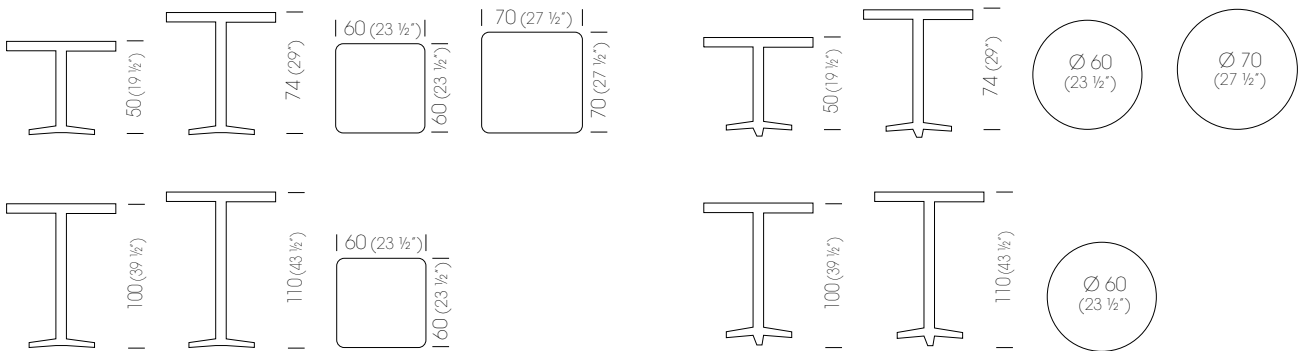

# ARKET PLUS

Forsix Design, 2020



## FRAME FINISHES

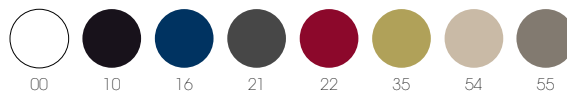

Steel table tops, three spokes bases made of co-injected metal and technopolymer. Stem and cross are made in aluminum, and provided with flip-top technopolymer joint.

Piani in acciaio, la base a tre razze costituita da una struttura in metallo co-iniettata con tecnopolimero. Colonna e crociera realizzate in alluminio, dotate di giunto per la rotazione del piano in tecnopolimero.

## STEEL TOP FINISHES

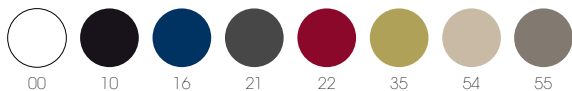

## AVAILABLE DIMENSIONS

ARKET PLUS H75 |  $\varnothing 60$

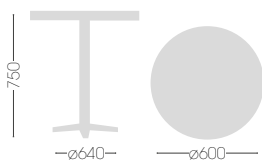

0,133 m<sup>3</sup> - 11,5 kg  
1 pc [carton]

ARKET PLUS H75 | 60x60

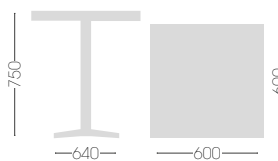

0,133 m<sup>3</sup> - 13,1 kg  
1 pc [carton]